

HOW TO PLAY

Don't Break the Ice®



Contents

2 Mallets
"Ice Blocks" (1 large, 32 small)
Ice Tray (2 Parts)
Polar Bear

For 2 to 4 Players • Ages 3 and Up

Object of the Game: Have fun tapping out the blocks of ice, but don't let the polar bear fall through! A little thinking will keep him from sinking!

GET READY!

1. Remove the blocks from the bag. Discard the bag.
2. Turn the two halves of the ice tray upside down and connect them as shown.

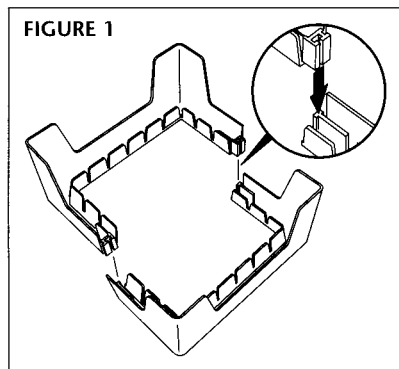

GET SET!

1. While the tray is still upside down, place the blocks into the ice tray with the open side of the blocks facing up. (The last one in each row has to be squeezed in.)
2. Put the large ice block into the tray also, any place you'd like.
Turn the tray rightside up. Place the base of the polar bear into the hole on the large ice block.

GO!

Take a mallet (share them if more than two of you play) and tap out a block of ice. You must continue with that same block until it falls through the tray, even if other blocks fall through before it or with it.

Take turns and use a little strategy because if the polar bear falls through the ice on your turn, you're out of the game. When that happens, set up the blocks for another round and start again.

YOU WIN!

If you are the last player left, after all the others have made the polar bear fall through the ice, you win the game!

Milton Bradley Company
P.O. Box 1247, East Longmeadow, MA 01028
© 1984, 1986, 1993, 1997 Milton Bradley Company.
All Rights Reserved. 4784-I